

JVC

SERVICE MANUAL

CD RECEIVER

KD-S621

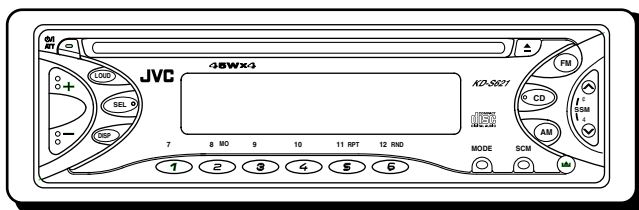
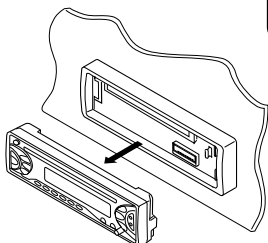

COMPACT
disc
DIGITAL AUDIO

Area Suffix

E ----- Continental Europe
EX ----- Central Europe

Contents

Safety precaution	1-2	Flow of functional	
Preventing static electricity	1-3	operation unit TOC read	1-12
Disassembly method	1-4	Maintenance of laser pickup	1-14
Adjustment method	1-11	Replacement of laser pickup	1-14
		Description of major ICs	1-15~26

Safety precaution

 **CAUTION** Burrs formed during molding may be left over on some parts of the chassis. Therefore, pay attention to such burrs in the case of performing repair of this system.

 **CAUTION** Please use enough caution not to see the beam directly or touch it in case of an adjustment or operation check.

Preventing static electricity

1. Grounding to prevent damage by static electricity

Electrostatic discharge (ESD), which occurs when static electricity stored in the body, fabric, etc. is discharged, can destroy the laser diode in the traverse unit (optical pickup). Take care to prevent this when performing repairs.

2. About the earth processing for the destruction prevention by static electricity

Static electricity in the work area can destroy the optical pickup (laser diode) in devices such as CD players. Be careful to use proper grounding in the area where repairs are being performed.

2-1 Ground the workbench

Ground the workbench by laying conductive material (such as a conductive sheet) or an iron plate over it before placing the traverse unit (optical pickup) on it.

2-2 Ground yourself

Use an anti-static wrist strap to release any static electricity built up in your body.

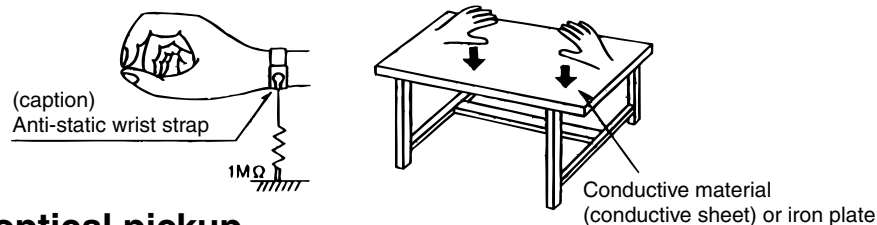

3. Handling the optical pickup

1. In order to maintain quality during transport and before installation, both sides of the laser diode on the replacement optical pickup are shorted. After replacement, return the shorted parts to their original condition. (Refer to the text.)
2. Do not use a tester to check the condition of the laser diode in the optical pickup. The tester's internal power source can easily destroy the laser diode.

4. Handling the traverse unit (optical pickup)

1. Do not subject the traverse unit (optical pickup) to strong shocks, as it is a sensitive, complex unit.
2. Cut off the shorted part of the flexible cable using nippers, etc. after replacing the optical pickup. For specific details, refer to the replacement procedure in the text. Remove the anti-static pin when replacing the traverse unit. Be careful not to take too long a time when attaching it to the connector.
3. Handle the flexible cable carefully as it may break when subjected to strong force.
4. It is not possible to adjust the semi-fixed resistor that adjusts the laser power. Do not turn it

Attention when traverse unit is decomposed

***Please refer to "Disassembly method" in the text for pick-up and how to detach the substrate.**

1. Solder is put up before the card wire is removed from connector on the CD substrate as shown in Figure.
(When the wire is removed without putting up solder, the CD pick-up assembly might destroy.)
2. Please remove solder after connecting the card wire with when you install picking up in the substrate.

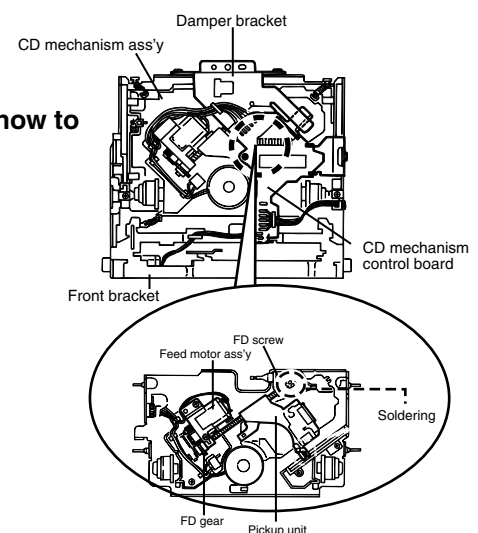

Disassembly method

<Main body>

■ Removing the front panel assembly (See Fig.1)

1. Press the eject button in the lower right part of the front panel. Remove the front panel assembly from the body.

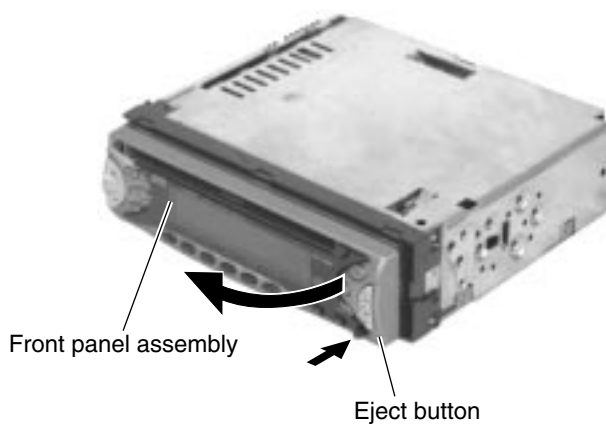

Fig.1

■ Removing the front chassis assembly (See Fig.2 and 3)

- Prior to performing the following procedure, remove the front panel assembly.
1. Release the four joint tabs **a** on both sides of the front chassis assembly and remove the front chassis assembly toward the front.

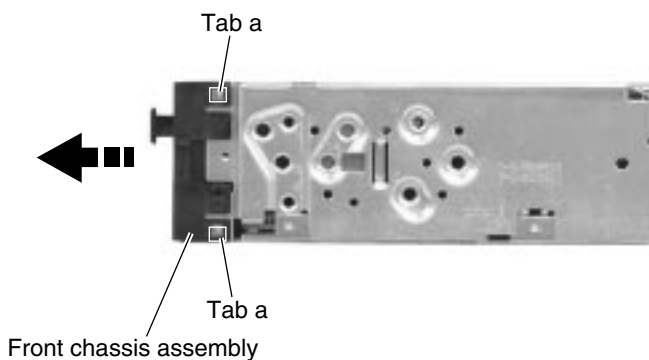

Fig.2

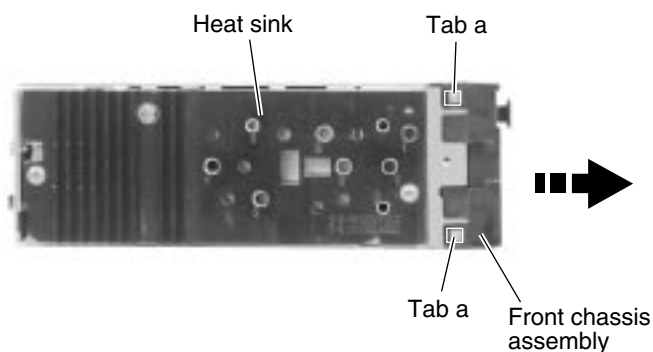

Fig.3

■ **Removing the heat sink (See Fig.4)**

1. Remove the three screws **A** on the left side of the body.

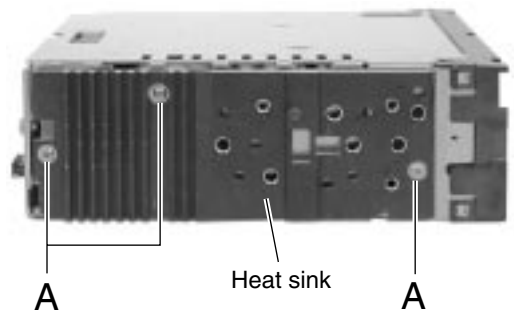

Fig.4

■ **Removing the bottom cover (See Fig.5 and 6)**

- Prior to performing the following procedure, remove the front panel assembly, the front chassis assembly and the heat sink.

1. Turn over the body and unjoint the five joints **b** with the bottom cover and the body using a screwdriver.

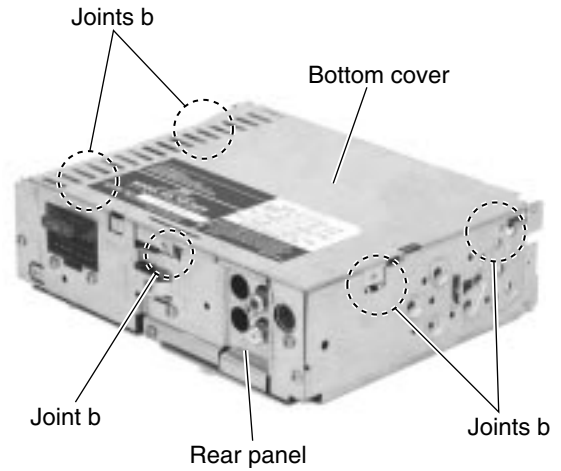

Fig.5

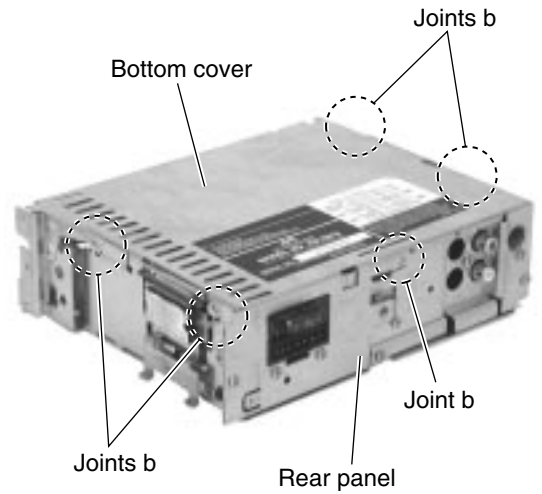

Fig.6

■ Removing the main board
(See Fig.7 and 8)

• Prior to performing the following procedure, remove the front panel assembly, the front chassis assembly, the heat sink and the bottom cover.

1. Remove the screw **B**, the four screws **C** and the three screws **D** attaching the rear panel on the back of the body. Remove the rear panel.
2. Remove the two screws **E** attaching the main board on the bottom of the body. Disconnect connector CN501 on the main board in the direction of the arrow.

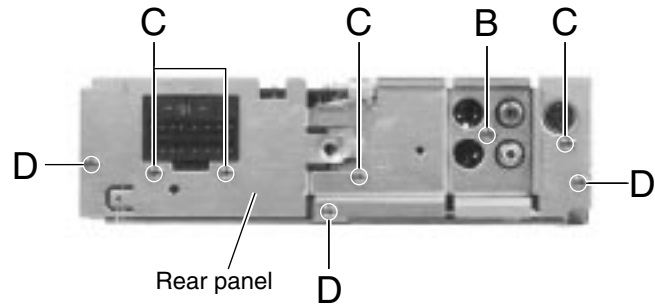

Fig.7

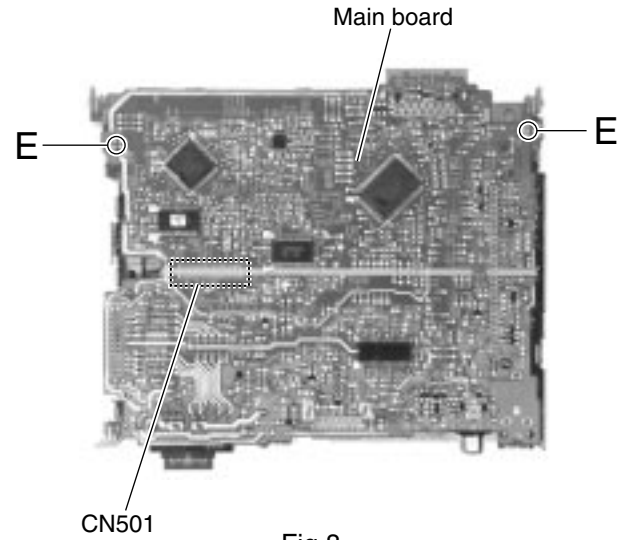

Fig.8

■ Removing the CD mechanism section
(See Fig.9)

• Prior to performing the following procedure, remove the front panel assembly, the front chassis assembly, the heat sink, the bottom cover and the main board.

1. Remove the three screws **F** attaching the cassette mechanism section on the back of the top chassis.

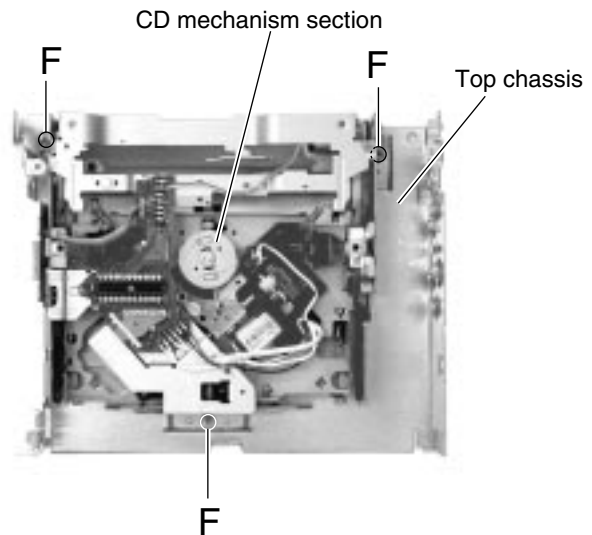

Fig.9

**■ Removing the control switch board
(See Fig.10 to 12)**

· Prior to performing the following procedure, remove the front panel assembly.

1. Remove the four screws **G** attaching the rear cover on the back of the front panel assembly.
2. Unjoint the nine joints **c** with the front panel and the rear cover.
3. Remove the control switch board on the back of the front panel.

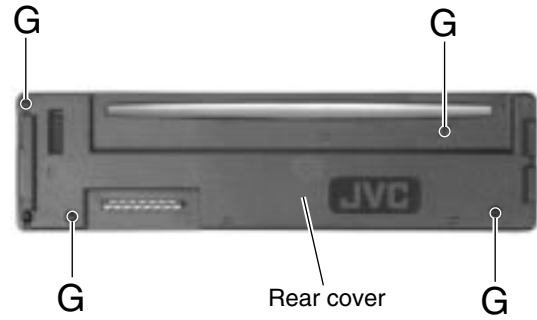

Fig.10

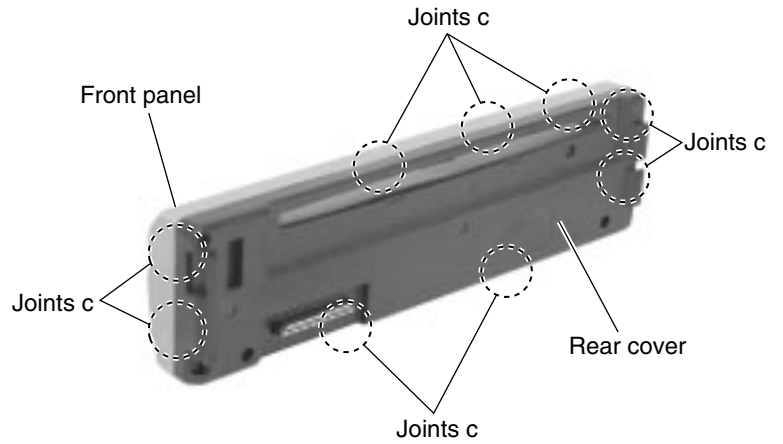

Fig.11

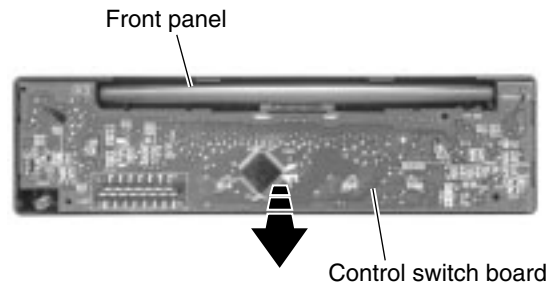

Fig.12

■ **Removing the CD mechanism control board(See Fig.1 and 2)**

Unsolder the part f and g on the CD mechanism control board.

Remove the stator fixing the CD mechanism control board and the damper bracket (To remove the stator smoothly, pick up the center part).

Remove the screw F attaching the CD mechanism control board.

Remove the CD mechanism control board in the direction of the arrow while releasing it from the two damper bracket slots i and the front bracket slot j.

Disconnect the flexible wire from connector on the pickup unit.

ATTENTION: Turn the FD gear in the direction of the arrow to move the entire pickup unit to the appropriate position where the flexible wire of the CD mechanism unit can be disconnected easily (Refer to Fig.2).

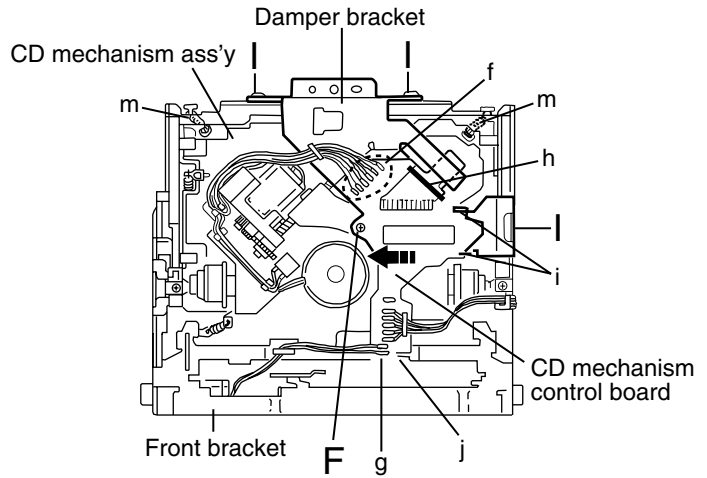

Fig.1

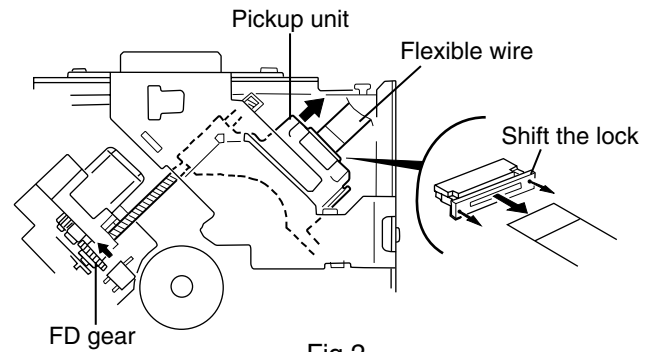

Fig.2

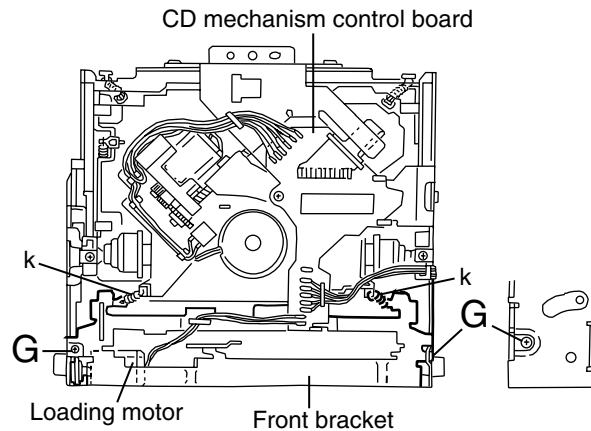

Fig.3

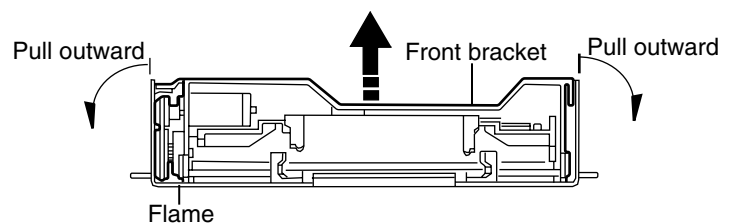

Fig.4

■ Removing the loading motor
(See Fig.3 to 5)

• Prior to performing the following procedure, remove the CD mechanism control board.

1. Remove the two springs k attaching the CD mechanism ass'y and the front bracket.
2. Remove the two screws G and the front bracket while pulling the flame outward.
3. Remove the belt and the screw H from the loading motor.

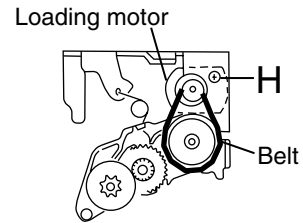

Fig.5

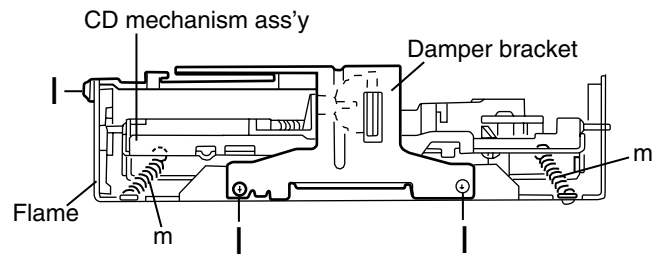

Fig.6

■ Removing the CD mechanism ass'y
(See Fig.1, 6 to 9)

• Prior to performing the following procedure, remove the CD mechanism control PWB and the front bracket (loading motor).

1. Remove the three screws I and the damper bracket.
2. Raise the both sides fix arms and move the fix plates in the direction of the arrow to place the four shafts I as shown in Fig.8 and 9.
3. Remove the CD mechanism ass'y and the two springs m attaching the flame.
4. Remove the two screws J and both sides rear damper brackets from the dampers. Detach the CD mechanism ass'y from the left side to the right side.

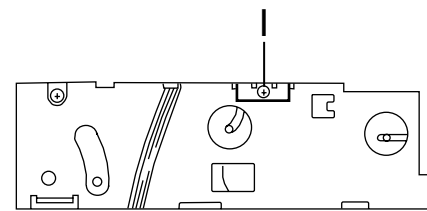

Fig.7

ATTENTION: The CD mechanism ass'y can be removed if only the rear damper bracket on the left side is removed.

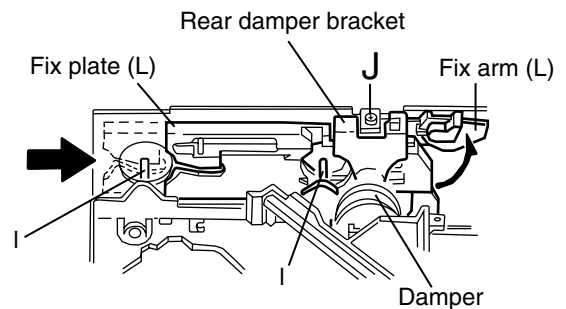

Fig.8

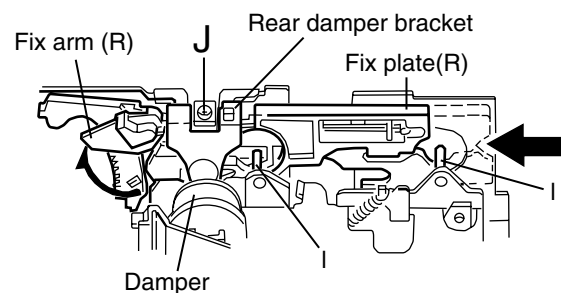

Fig.9

■ Removing the feed motor ass'y
(See Fig.10)

- Prior to performing the following procedure, remove the CD mechanism control board, the front bracket (loading motor) and the CD mechanism ass'y.

1. Remove the two screws K and the feed motor ass'y.

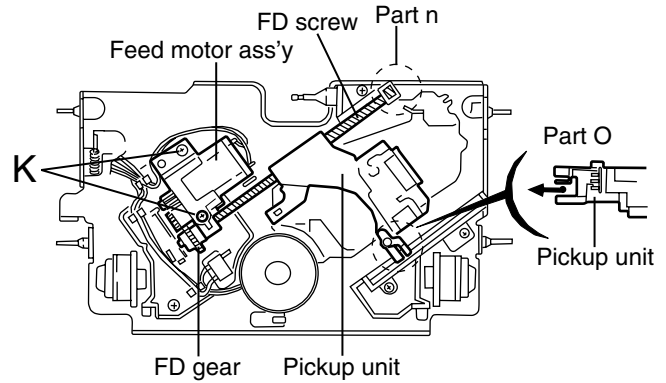

Fig.10

■ Removing the pickup unit
(See Fig.10 and 11)

- *Prior to performing the following procedure, remove the CD mechanism control board, the front bracket (loading motor), the CD mechanism ass'y and the feed motor ass'y.

1. Detach the FD gear part of the pickup unit upward. Then remove the pickup unit while pulling out the part n of the FD screw.

ATTENTION: When reattaching the pickup unit, reattach the part o of the pickup unit, then the part n of the FD screw.

2. Remove the screw L attaching the nut push spring plate and the pickup mount nut from the pickup unit. Pull out the FD screw.

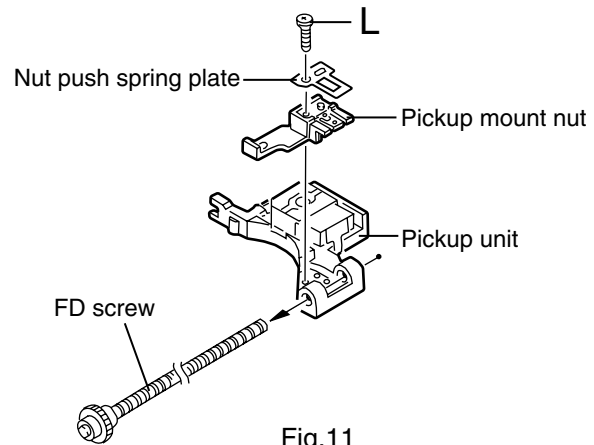

Fig.11

■ Removing the spindle motor
(See Fig.12 and 13)

- Prior to performing the following procedure, remove the CD mechanism control board, the front bracket (loading motor), the CD mechanism ass'y and the feed motor ass'y.

1. Turn up the CD mechanism ass'y and remove the two springs p on both sides of the clamber arms. Open the clamber arm upward.

2. Turn the turn table, and remove the two screws M and the spindle motor.

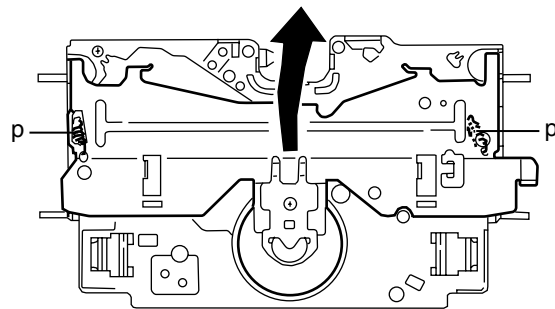

Fig.12

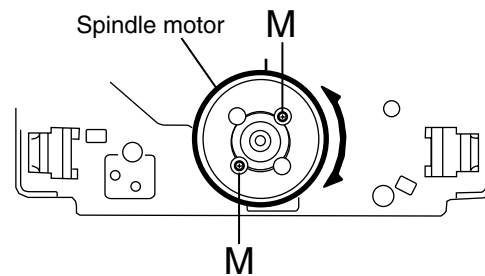

Fig.13

Adjustment method

■ Test instruments required for adjustment

1. Digital oscilloscope (100MHz)
2. AM Standard signal generator
3. FM Standard signal generator
4. Stereo modulator
5. Electric voltmeter
6. Digital tester
7. Tracking offset meter
8. Test Disc JVC :CTS-1000
9. Extension cable for check
EXTGS004-26P × 1

■ Standard volume position

Balance and Bass & Treble volume : Indication "0"
Loudness : OFF

■ Frequency Band

FM 87.5MHz ~ 108.0MHz
MW 522kHz ~ 1620 kHz
LW 144kHz ~ 279kHz

■ Dummy load

Exclusive dummy load should be used for AM, and FM. For FM dummy load, there is a loss of 6dB between SSG output and antenna input. The loss of 6dB need not be considered since direct reading of figures are applied in this working standard.

■ Standard measuring conditions

Power supply voltage DC14.4V(10.5~16V)
Load impedance 4 Ω (2 Speakers connection)
Line out load impedance 20k Ω
Output Level Line out 2.0V (Vol. MAX)

■ How to connect the extension cable for adjusting

* The cardboard is cut in a suitable size.
uses for the insulation stand of mechanism.

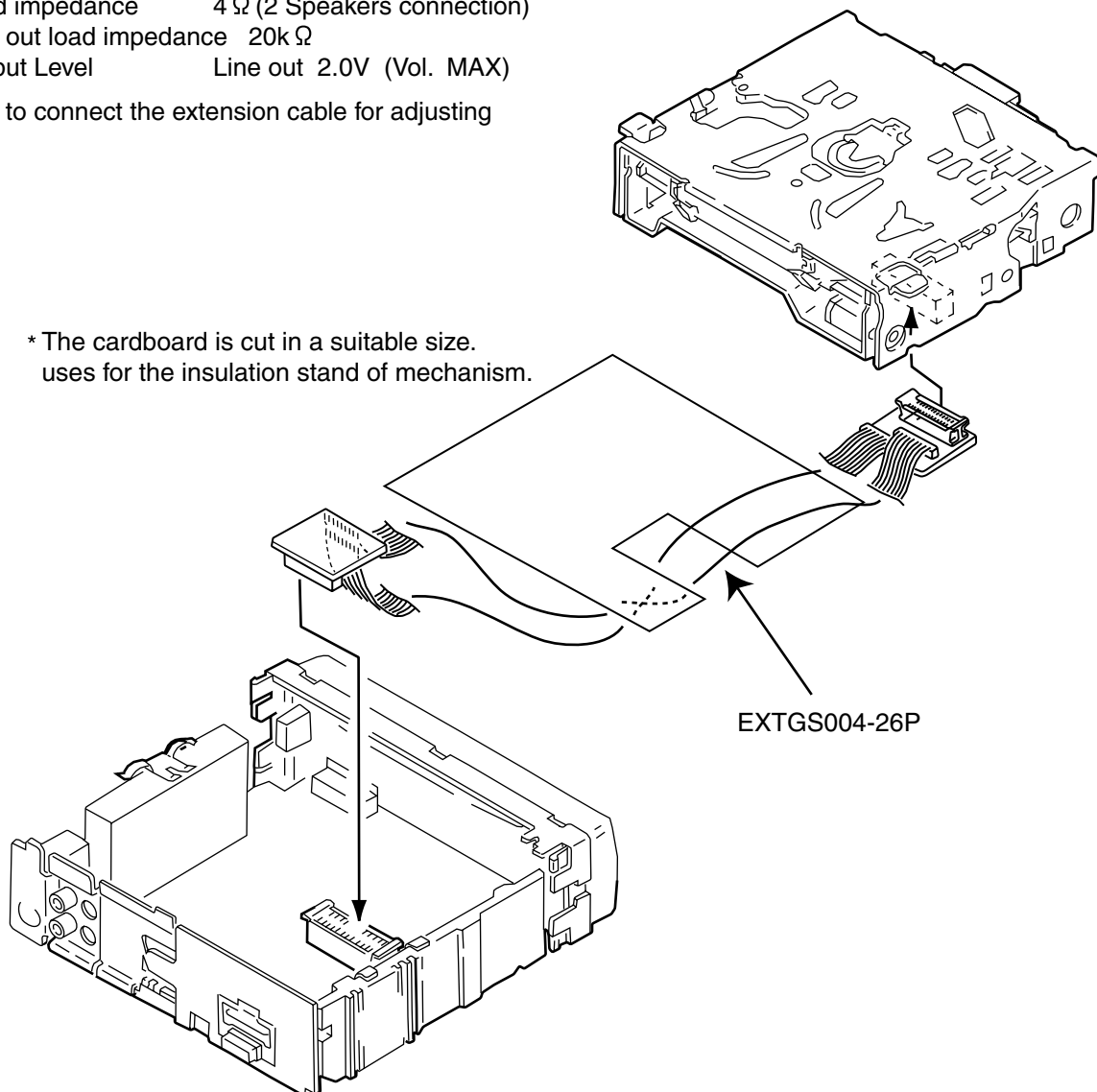

Flow of functional operation until TOC read

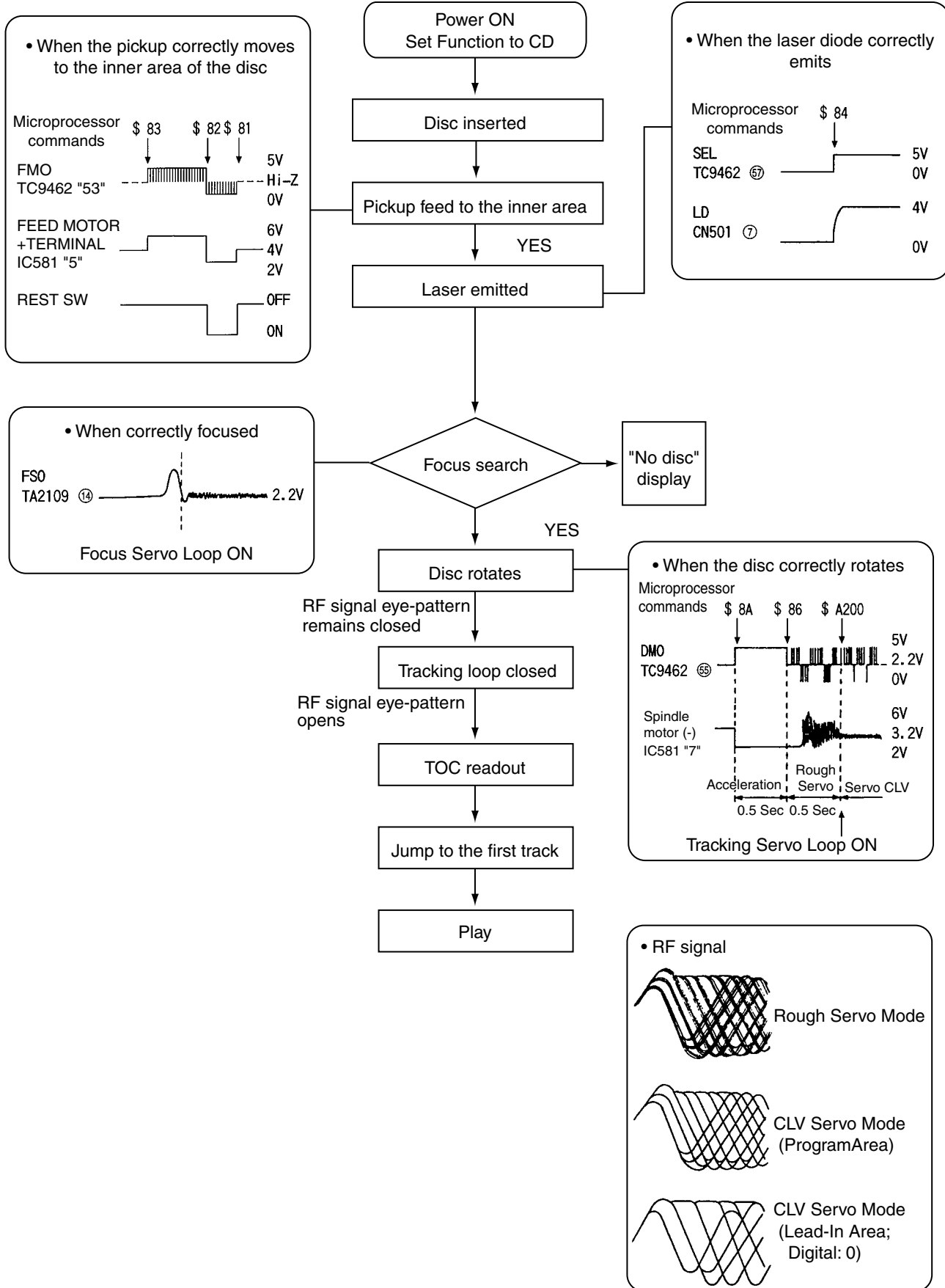

■ Feed Section

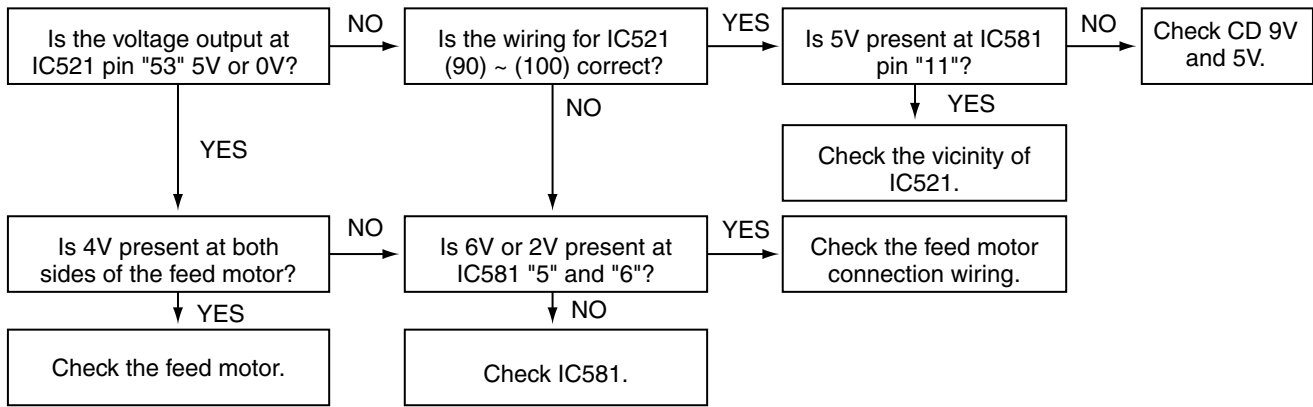

■ Focus Section

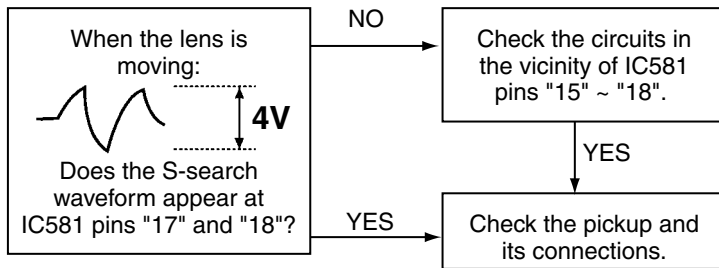

■ Spindle Section

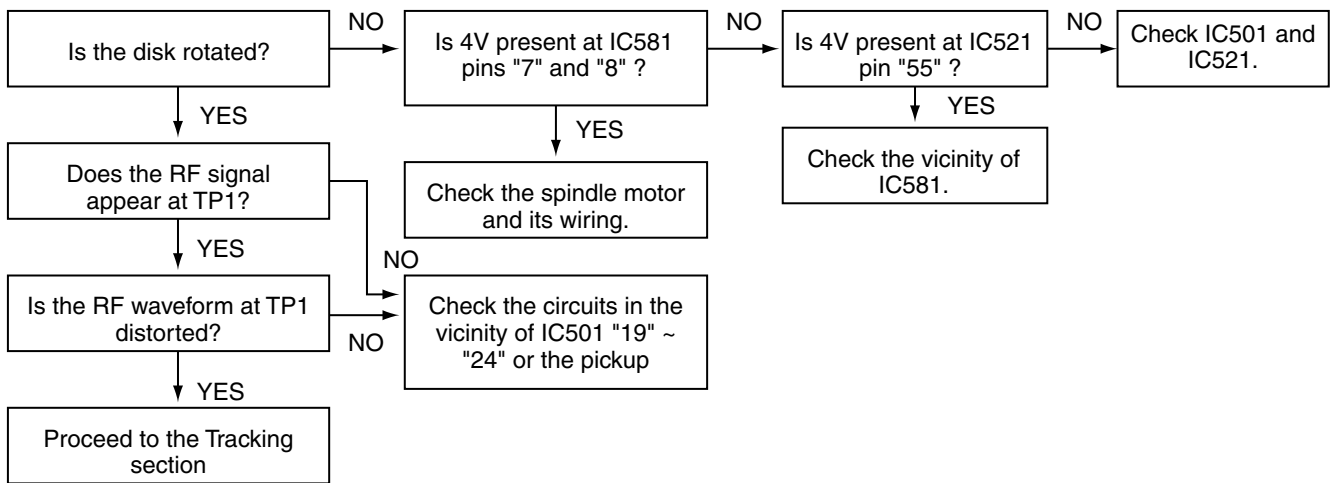

■ Tracking Section

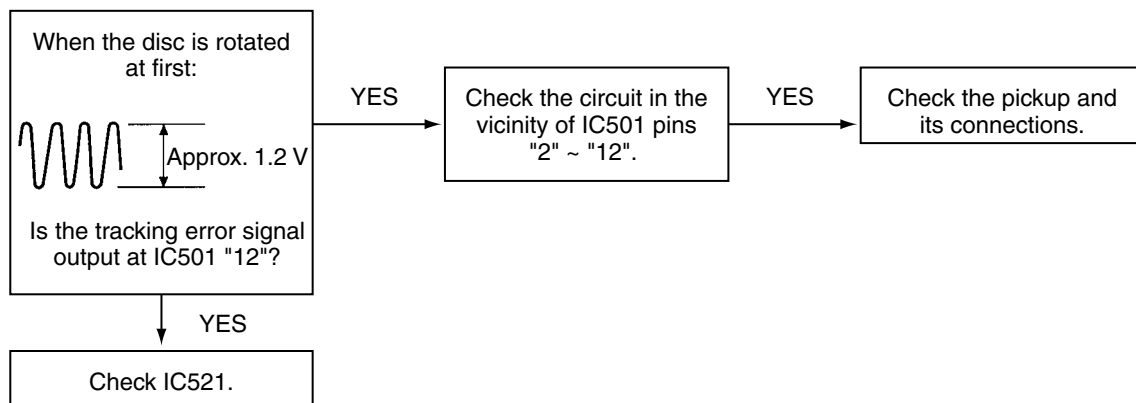

Maintenance of laser pickup

(1) Cleaning the pick up lens
 Before you replace the pick up, please try to clean the lens with a alcohol soaked cotton swab.

(2) Life of the laser diode
 When the life of the laser diode has expired, the following symptoms will appear.
 (1) The level of RF output (EFM output:amplitude of eye pattern) will be low.

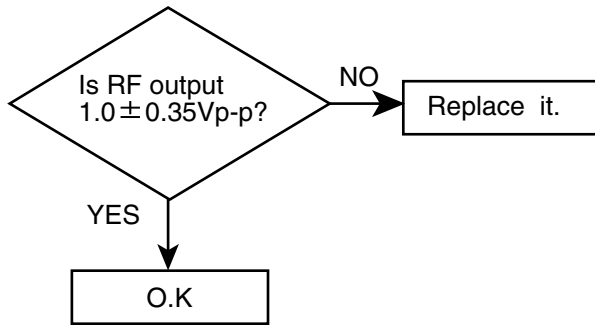

Replacement of laser pickup

(3) Semi-fixed resistor on the APC PC board
 The semi-fixed resistor on the APC printed circuit board which is attached to the pickup is used to adjust the laser power. Since this adjustment should be performed to match the characteristics of the whole optical block, do not touch the semi-fixed resistor.
 If the laser power is lower than the specified value, the laser diode is almost worn out, and the laser pickup should be replaced.
 If the semi-fixed resistor is adjusted while the pickup is functioning normally, the laser pickup may be damaged due to excessive current.

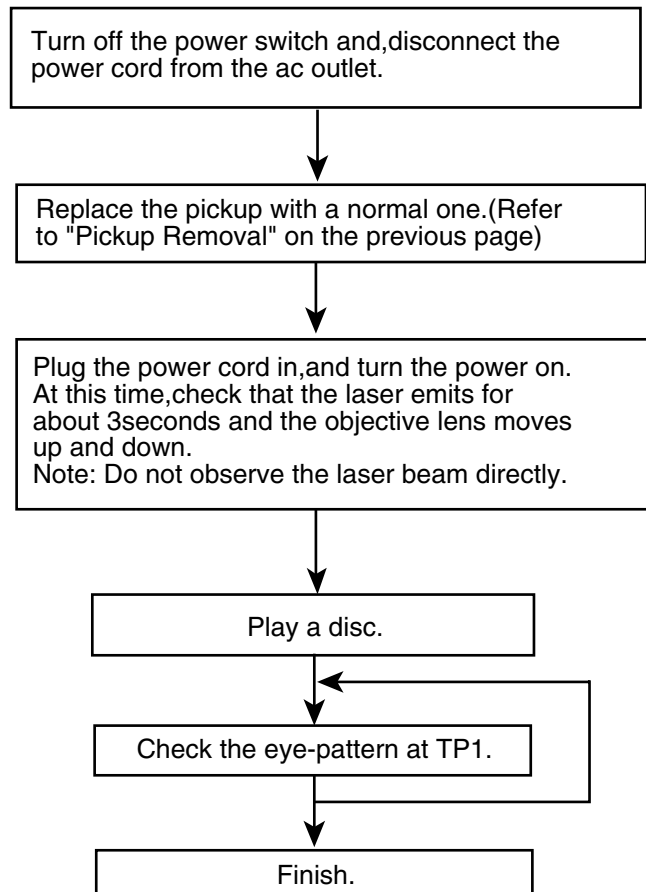

Description of major ICs

■ HA13164A(IC901) : Regulator

1.Pin layout

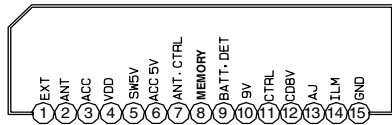

2.Block diagram

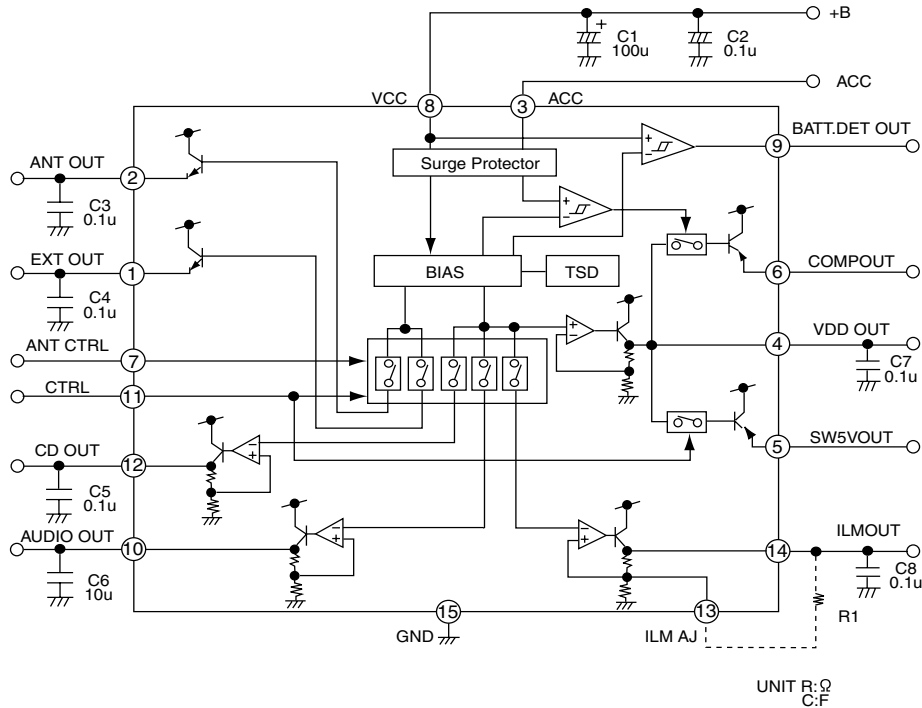

note1) TAB (header of IC)
connected to GND

3.Pin function

Pin No.	Symbol	Function
1	EXT	Output voltage is VCC-1 V when M or H level applied to CTRL pin.
2	ANT	Output voltage is VCC-1 V when M or H level to CTRL pin and H level to ANT-CTRL.
3	ACC	Connected to ACC.
4	VDD	Regular 5.7V.
5	SW5V	Output voltage is 5V when M or H level applies to CTRL pin.
6	ACC5V	Output for ACC detector.
7	ANT CTRL	L:ANT output OFF , H:ANT output ON
8	MEMORY	Connected to VCC.
9	BATT DET	Low battery detect.
10	9V	Output voltage is 9V when M or H level applied to CTRL pin.
11	CTRL	L:BIAS OFF, M:BIAS ON, H:CD ON
12	CD8V	Output voltage is 8V when H level applied to CTRL pin.
13	AJ	Adjustment pin for ILM output voltage.
14	ILMI	Output voltage is 10V when M or H level applies to CTRL pin.
15	GND	Connected to GND.

■ AN8806SB-W (IC501) : RF & Servo amp.

1.Pin layout

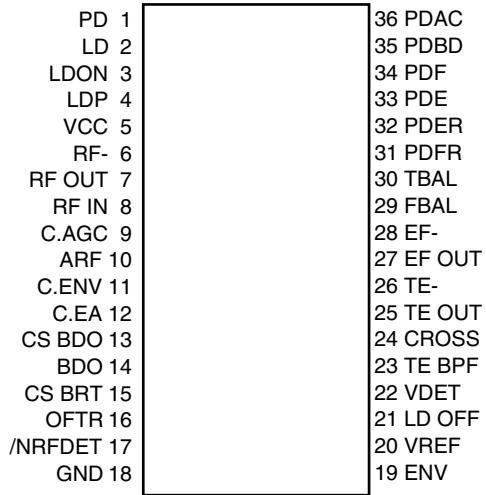

2.Block diagram

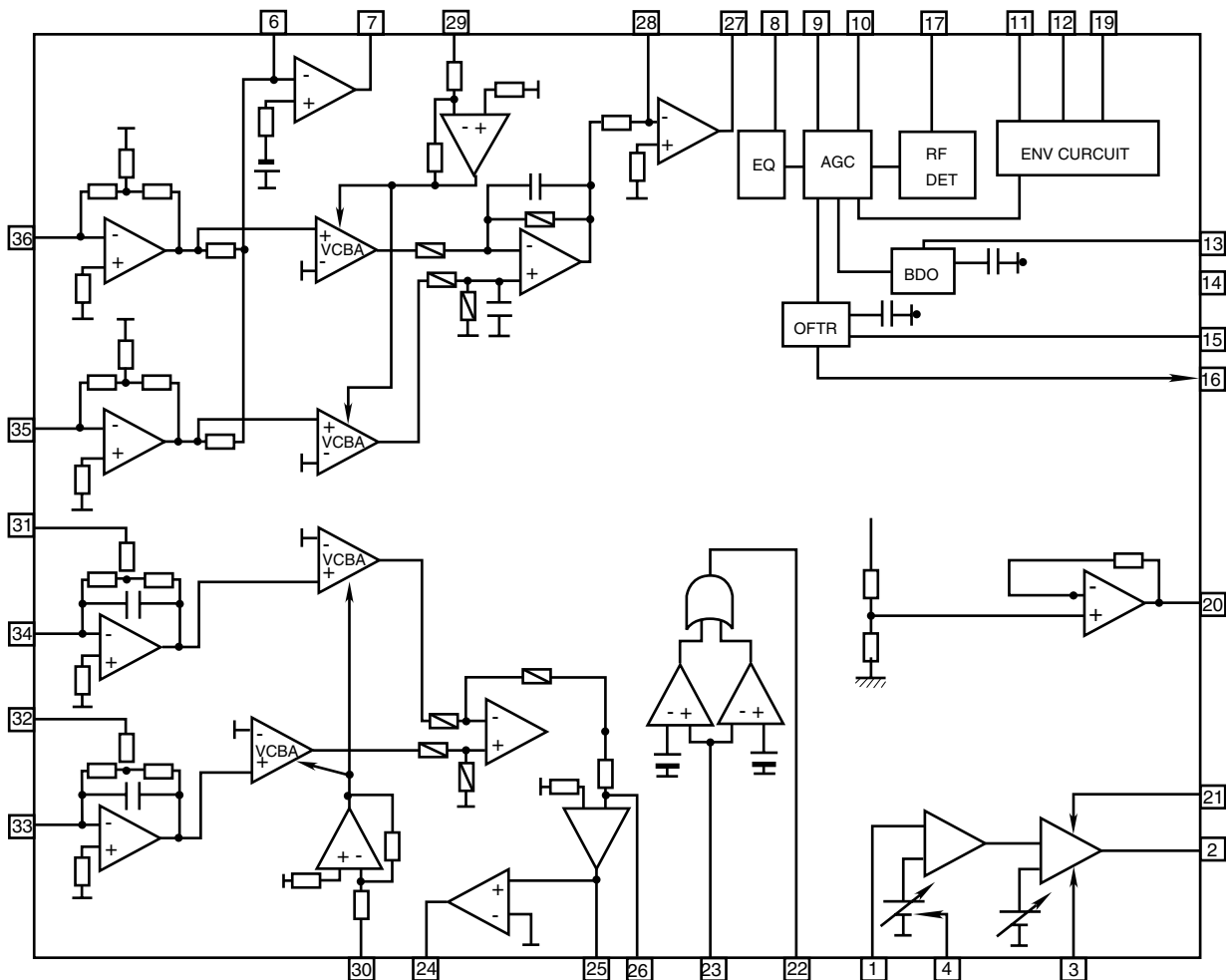

3. Pin function

AN8806SB-W

Pin No.	Symbol	I/O	Function
1	PD	I	APC amp . Input terminal
2	LD	O	APC amp . Output terminal
3	LD ON	I	LD ON/OFF control terminal
4	LDP	--	Connect to GND
5	VCC	--	Power supply
6	RF-	I	RF amp . Reversing input terminal
7	RF OUT	O	RFamp . Output terminal
8	RF IN	I	AGC input terminal
9	C.AGC	I/O	AGC loop filter connection terminal
10	ARF	O	ARF output terminal
11	C.ENV	I/O	RF detection capacity connection terminal
12	C.EA	I/O	HPF-amp capacity connection terminal
13	CS BDO	I/O	Capacity connection terminal for RF discernment side envelope detection
14	BDO	O	BDO output terminal
15	CS BRT	I/O	Capacity connection terminal for RF discernment side envelope detection
16	OFTR	O	OFTR output terminal
17	/NRFDET	O	RFDET output terminal
18	GND	--	Connect to GND
19	ENV	O	3TENV output terminal
20	VREF	O	VREF output terminal
21	LD OFF	--	APC OFF control terminal
22	VDET	O	VDET output terminal
23	TE BPF	I	VDET input terminal
24	CROSS	O	CROSS output terminal
25	TE OUT	O	TE amp . Output terminal
26	TE-	I	FE amp . Reversing input terminal
27	FE OUT	O	FE amp . output terminal
28	FE-	I	FE amp . Reversing input terminal
29	FBAL	I	F.BAL control terminal
30	TBAL	I	T.BAL control terminal
31	PDFR	I/O	I-V amp conversion resistance adjustment terminal
32	PDER	I/O	I-V amp conversion resistance adjustment terminal
33	PDF	I	I-V amp input terminal
34	PDE	I	I-V amp input terminal
35	PD BD	I	I-V amp input terminal
36	PD AC	I	I-V amp input terminal

■ LA4743K(IC321):Power AMP

1.Block diagram

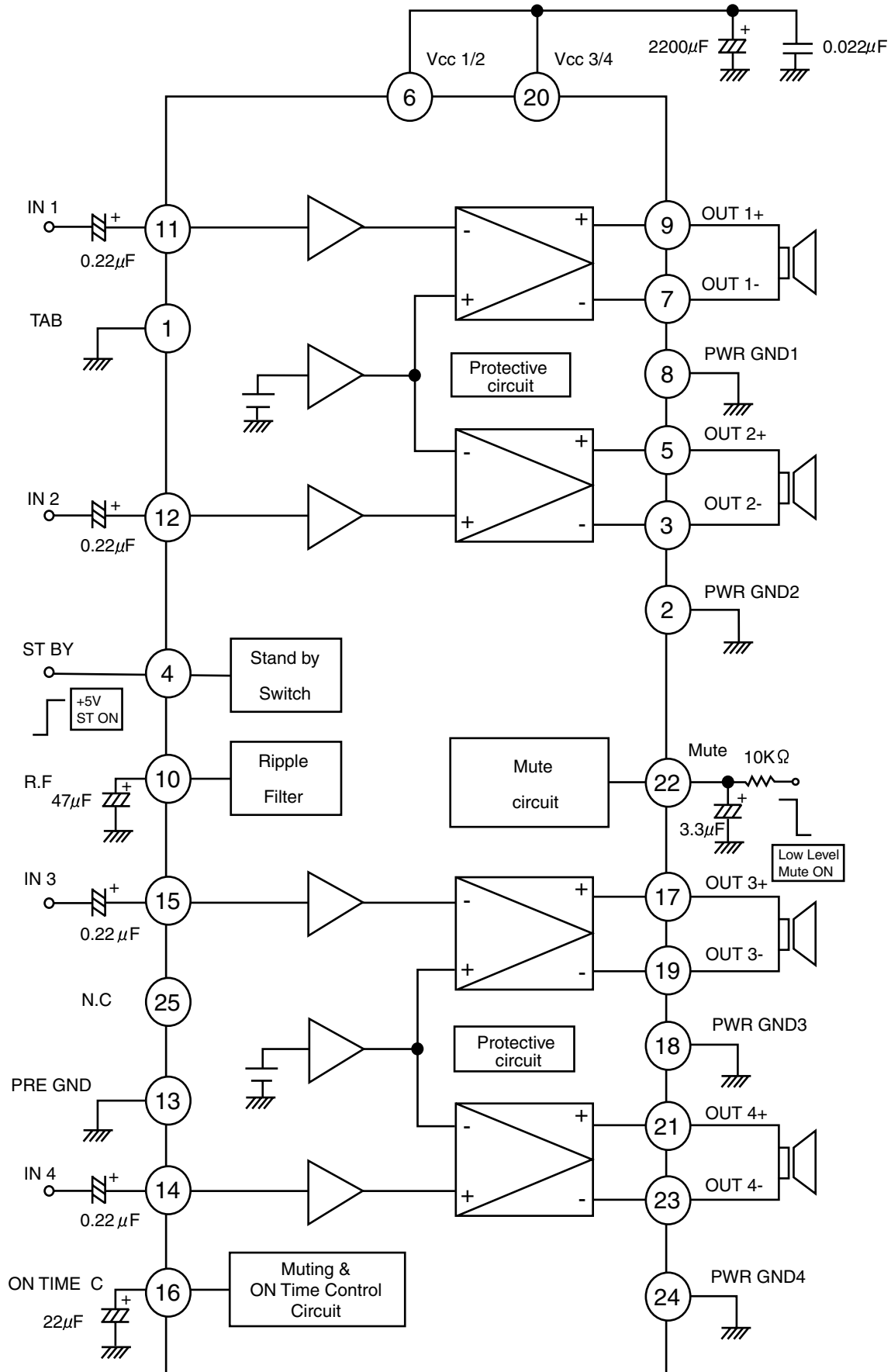

2.Terminal layout

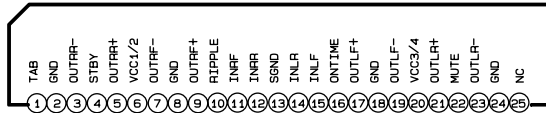

3.Pin function

LA4743K

Pin No.	Symbol	Function
1	TAB	Header of IC
2	GND	Power GND
3	OUTRR-	Outpur(-) for front Rch
4	STBY	Stand by input
5	OUTRR+	Output (+) for front Rch
6	VCC1/2	Power input
7	OUTRF-	Output (-) for rear Rch
8	GND	Power GND
9	OUTRF+	Output (+) for rear Rch
10	RIPPLE	Ripple filter
11	INRF	Rear Rch input
12	INRR	Front Rch input
13	SGND	Signal GND
14	INLR	Front Lch input
15	INLF	Rear Lch input
16	ONTIME	Power on time control
17	OUTLF+	Output (+) for rear Lch
18	GND	Power GND
19	OUTLF-	Output (-) for rear Lch
20	VCC3/4	Power input
21	OUTLR+	Output (+) for front
22	MUTE	Muting control input
23	OUTLR-	Output (-) for front
24	GND	Power GND
25	NC	Non connection

■ LA6567H-X(IC541):CD DRIVE

1.Pin layout & blockdiagram

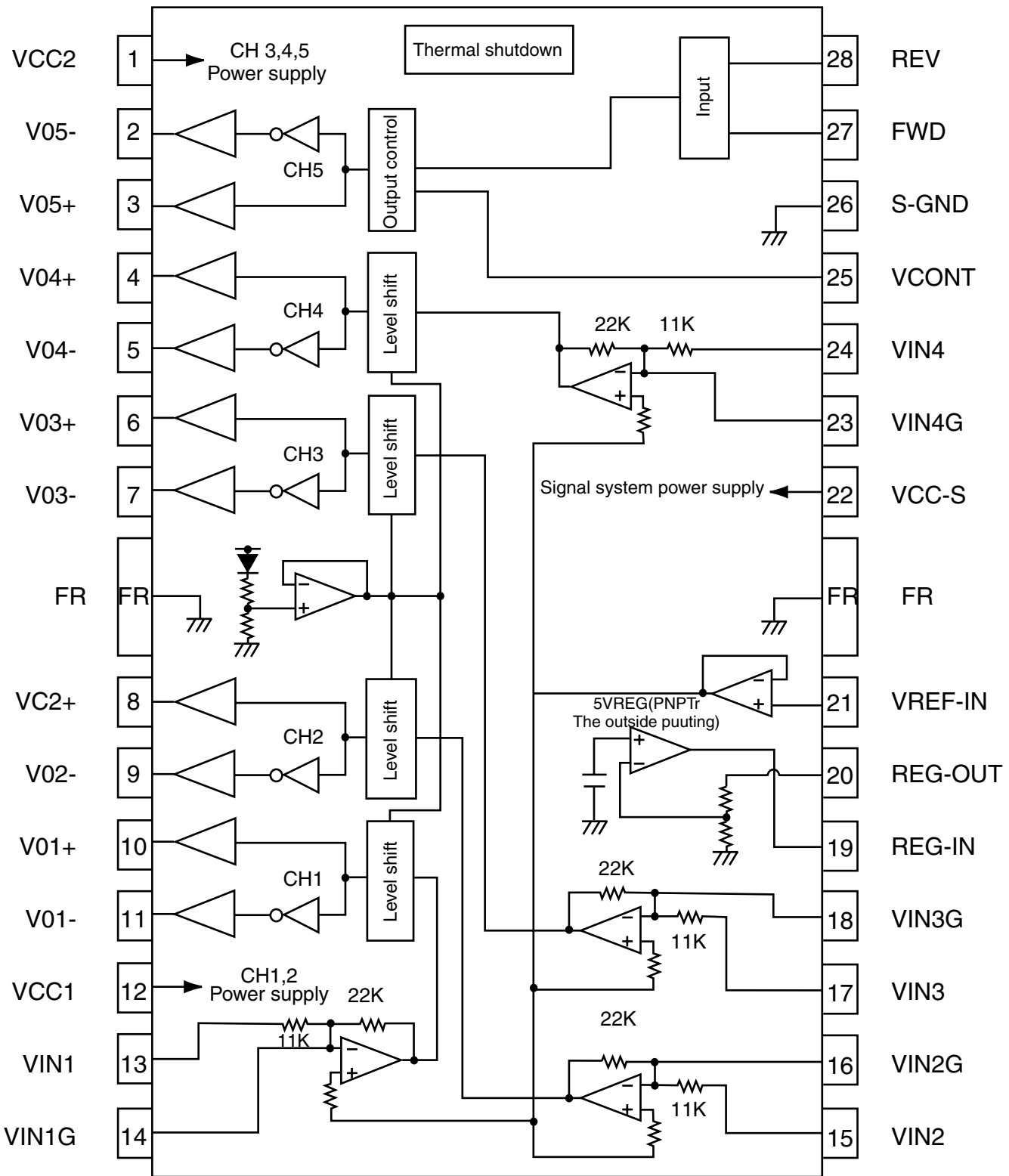

2. Pin function

LA6567H-X(2/2)

Pin no.	Symbol	Function
1	VCC2	CH3,4,5 Power supply(It is short with VCC1,VCC-S)
2	V05-	Loading output(-)
3	V05+	Loading terminal (+)
4	V04+	CH4 Output terminal(+)
5	V04-	CH4 Output terminal(-)
6	V03+	CH3 Output terminal(+)
7	V03-	CH3 Output terminal(-)
8	V02+	CH2 Output terminal(+)
9	V02-	CH2 Output terminal(-)
10	V01+	CH1 Output terminal(+)
11	V01-	CH1 Output terminal(-)
12	VCC1	CH1,2(BTL) Power supply(It is short with VCC-S,VCC2)
13	VIN1	CH1 Input terminal
14	VIN1G	CH1 Input terminal(For gain adjustment)
15	VIN2	CH2 Input terminal
16	VIN2G	CH2 Input terminal(For gain adjustment)
17	VIN3	CH3 Input terminal
18	VIN3G	CH3 Input terminal(For gain adjustment)
19	REG-IN	Regulator terminal(Outside putting PNP base)
20	REG-OUT	Regulator terminal(Outside putting PNP collector)
21	VREF-IN	Standard voltage input terminal
22	VCC-S	Signal system power supply(It is short with VCC1,VCC2)
23	VIN4G	CH4 Input terminal(For gain adjustment)
24	VIN4	CH4 Input terminal
25	VCONT	5CH(VLO) Output voltage set terminal
26	S-GND	Signal system GND
27	FWD	5CH(VLO)Signal output switch terminal(FWD),Input of logic of loading part
28	REV	5CH(VLO)Signal output switch terminal(REV), Input of logic of loading part

* Frame(FR)at the center becomes system GND.

* Please be short-circuited on the outside and use the terminal of the power supply system and three terminals of VCC-S, VCC1,VCC2.

■ LC72366-9A73 (IC801) : System CPU

1. Pin layout

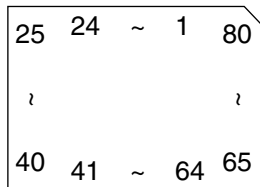

2. Pin function

Pin No.	Symbol	I/O	Function
1	XIN	I	Crystal oscillator input port
2	TEST2	I	Connect to ground
3	J-BUS SI	-	No use
4	J-BUS SO	-	No use
5	J-BUS SCK	-	No use
6	J-BUS I/O	-	No use
7	SUBQ	I/O	CD LSI subcode data input
8		-	No use
9	SQCK	I/O	CD LSI subcode clock
10	RESET	I	Micon reset pin
11	LCD SI	-	No use
12	LCD SO	O	LCD driver data output
13	LCD SCK	O	LCD driver clock signal
14	LCD CE	O	LCD driver chip enable port
15	FM ILLUMI	-	No use
16	AM ILLUMI	-	No use
17	CD ILLUMI	-	No use
18	DIMMER OUT	-	No use
19	LM0	O	CD loading motor output
20	LM1	O	CD loading motor output
21		-	No use
22		-	No use
23		-	No use
24	KS2	O	Output for initial setting diode matrix
25	KS1	O	Output for initial setting diode matrix
26	KS0	O	Output for initial setting diode matrix
27	DETACH	I	Front panel detect
28	K2	-	No use
29	K1	I	Input for initial setting diode matrix
30	K0	I	Input for initial setting diode matrix
31	Vdd	-	5V power supply port (+B)
32	SW2	I	CD mechanism detect switch
33	CD LSI RESET	O	CD LSI reset
34	MCLK	O	CD LSI command clock signal
35	MDATA	O	CD LSI command data output
36	MLD	O	CD LSI command load signal
37		-	No use
38		-	No use
39	SCL	O	E.volume clock output
40	SDA	O	E.volume data output

Pin No.	Port Name	I/O	Function
41	CD ON	-	CD 8V supply on
42	RELAY	-	5V power control
43	BLKCK	I	Sub-code/block/clock signal output
44	BEEP	-	No use
45	SW4	I	CD mechanism detect switch
46	SW1	I	CD mechanism detect switch
47	SW3	I	CD mechanism detect switch
48	REST	I	CD pickup rest position
49	FLOCK	I	Focus lock signal output Active:Low
50	TLOCK	I	Tracking lock signal output Active :low
51	CD SENSE	I	CD LSI sense signal
52	STATUS	I	CD LDI status signal
53	P.SAVES2	I	power save 2:+B detect
54	SD/ST	I	Station detection, Stereo signal input H:SD
55	REMOCON	I	Remocon input
56	J BUS INT	-	No use
57	BAND	O	FM/AM band selection
58	MONO	-	FM mono selection
59	IFRQ/AGC	O	During FM auto search, IF request output H after SD detected. During AM auto search, AGC output
60	MUTE	O	Muting switch
61	LEVEL	I	Level meter input
62	S.METER	I	S meter input
63	KEY CHANGE	-	Control to GND
64	KEY2	I	Key 2 input port
65	KEY1	I	Key 1 input port
66	KEY0	I	Key 0 input port
67	P.SAVE1	I	Power save 1, ACC power detection
68	SENSE	I	Voltage sensor port
69		-	No use
70	FM IF COUNT	I	FM frequency detecting
71	NC	-	No use
72	NC	-	No use
73	Vdd	-	5V power supply (+B)
74	AM OSC	I	No use
75	FM OSC	I	FM limited signal input
76	VSS	-	Ground port for power supply
77	NC	-	No use
78	E0	O	Error signal output port for PLL
79	TEST1	-	Test port for LSI, To connect ground
80	XOUT	O	4.5MHz crystal oscillator output

■ LC75823W (IC601) : LCD driver

1. Pin Layout & Symbol

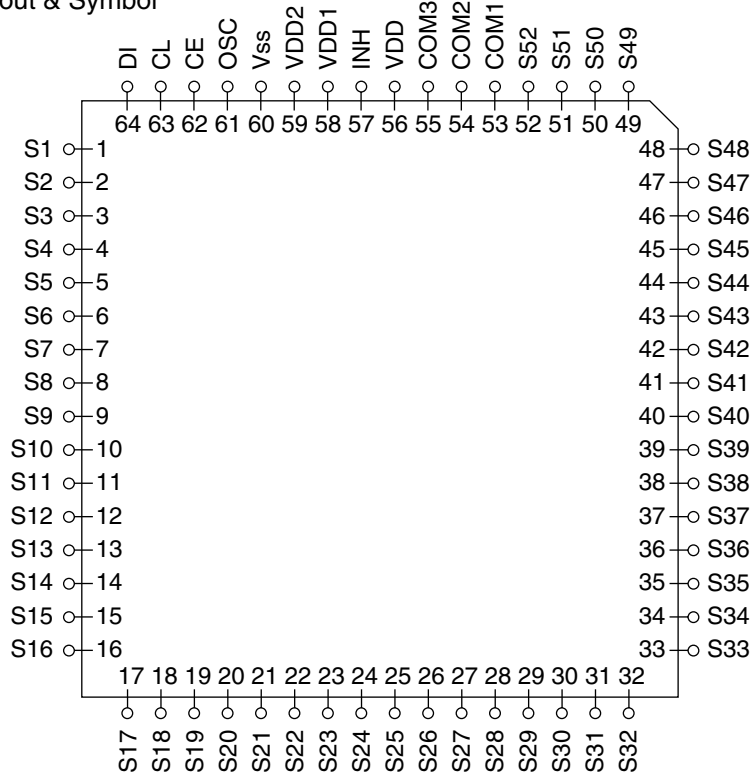

2. Pin Function

Pin No.	Symbol	I/O	Function
1 to 52	S1 to S52	O	Segment output pins used to display data transferred by serial data input.
53 to 55	COM1 to COM3	O	Common driver output pins. The frame frequency is given by : $t_0 = (f_{osc}/384)Hz$.
56	VDD	--	Power supply connection. Provide a voltage of between 4.5 and 6.0V.
57	\overline{INH}	I	Display turning off input pin. $\overline{INT} = "L"$ (Vss) ----- off (S1 to S52, COM1 to COM3="L") $\overline{INT} = "H"$ (VDD)----- on Serial data can be transferred in display off mode.
58	VDD1	I	Used for applying the LCD drive 2/3 bias voltage externally. Must be connected to VDD2 when a 1/2 bias drive scheme is used.
59	VDD2	I	Used for applying the LCD drive 1/3 bias voltage externally. Must be connected to VDD1 when a 1/2 bias drive scheme is used.
60	Vss	--	Power supply connection. Connect to GND.
61	OSC	I/O	Oscillator connection. An oscillator circuit is formed by connecting an external resistor and capacitor at this pin.
62	CE		Serial data interface connection CE : Chip enable
63	CL	I	to the controller. CL : Sync clock
64	DI		DI : Transfer data

TEA6320T-X (IC301) : E.volume

1.Pin layout

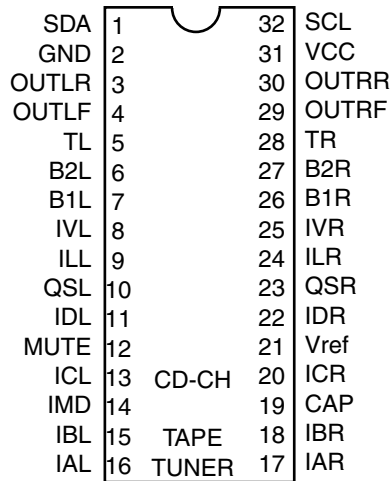

2.Block diagram

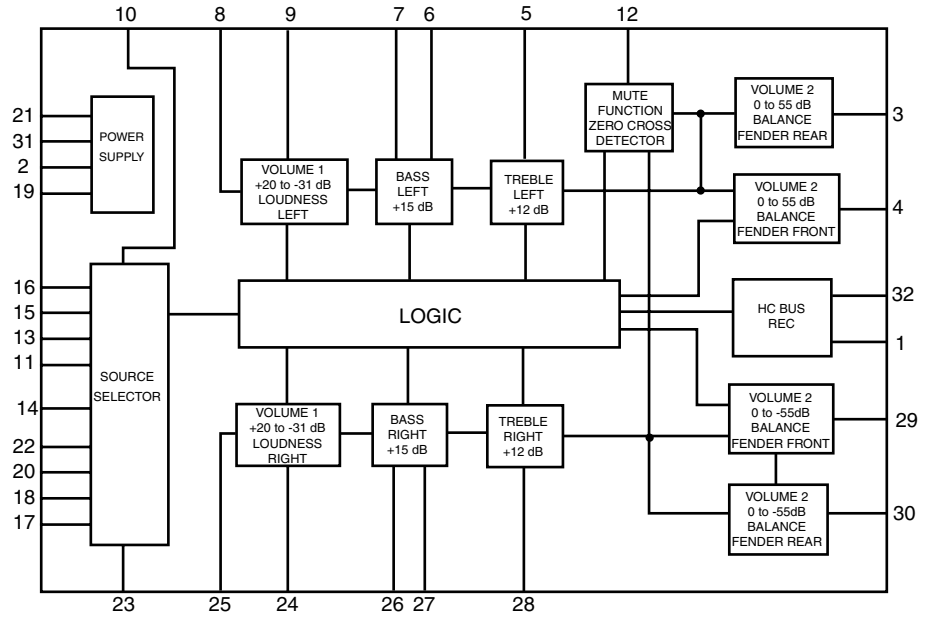

3.Pin functions

Pin No.	Symbol	I/O	Functions	Pin No.	Symbol	I/O	Functions
1	SDA	I/O	Serial data input/output.	17	IAR	I	Input A right source.
2	GND	-	Ground.	18	IBR	I	Input B right source.
3	OUTLR	O	output left rear.	19	CAP	-	Electronic filtering for supply.
4	OUTLF	O	output left front.	20	ICR	I	Input C right source.
5	TL	I	Treble control capacitor left channel or input from an external equalizer.	21	Vref	-	Reference voltage (0.5Vcc)
6	B2L	-	Bass control capacitor left channel or output to an external equalizer.	22	IDR	-	Not used
7	B1L	-	Bass control capacitor left channel.	23	QSR	O	Output source selector right channel.
8	IVL	I	Input volume 1. left control part.	24	ILR	I	Input loudness right channel.
9	ILL	I	Input loudness. left control part.	25	IVR	I	Input volume 1. right control part.
10	QSL	O	Output source selector. left channel.	26	B1R	-	Bass control capacitor right channel
11	IDL	-	Not used	27	B2R	O	Bass control capacitor right channel or output to an external equalizer.
12	MUTE	-	Not used	28	TR	I	Treble control capacitor right channel or input from an external equalizer.
13	ICL	I	Input C left source.	29	OUTRF	O	Output right front.
14	IMO	-	Not used	30	OUTRR	O	Output right rear.
15	IBL	I	Input B left source.	31	Vcc	-	Supply voltage.
16	IAL	I	Input A left source.	32	SCL	I	Serial clock input.

■ NJM4565M-WE (IC151) : Ope. amp

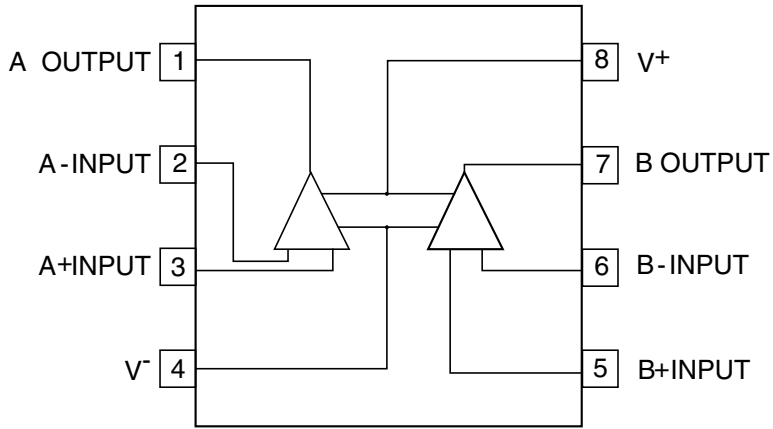



VICTOR COMPANY OF JAPAN, LIMITED

MOBILE ELECTRONICS DIVISION

PERSONAL & MOBILE NETWORK BUSINESS UNIT. 10-1,1Chome,Ohwatari-machi,Maebashi-city,371-8543,Japan